

# Door Grille

## Technical Specification Sheet Door Grille Range of Products

### Features

- Used for relief air
- Door mounted
- Aluminium construction
- Standard finish is natural anodised
- Other colours available upon request
- Suits door thicknesses 32 to 45mm
- Screw-less fixing for aesthetically pleasing appearance
- Available in vandal proof (made to order)



### Stock Sizes

DG3015 (300 x 150)  
DG6015 (600 x 150)  
DG6020 (600 x 200)

DG6025 (600 x 250)  
DG6030 (600 x 300)  
DG6040 (600 x 400)

DG6045 (600 x 450)  
DG6060 (600 x 600)

### Explanation of Part Number Structure

Product Group	Size (A x B)
Door Grille	300mm x 150mm
DG	3015
<b>DG3015</b>	



\*Refer web site for details



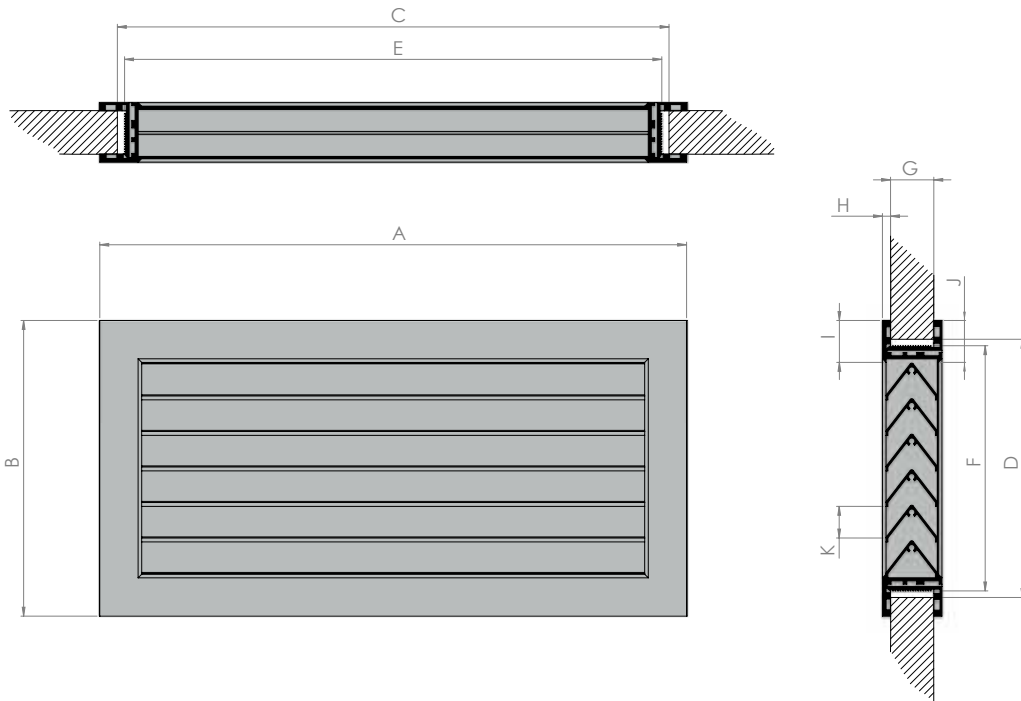
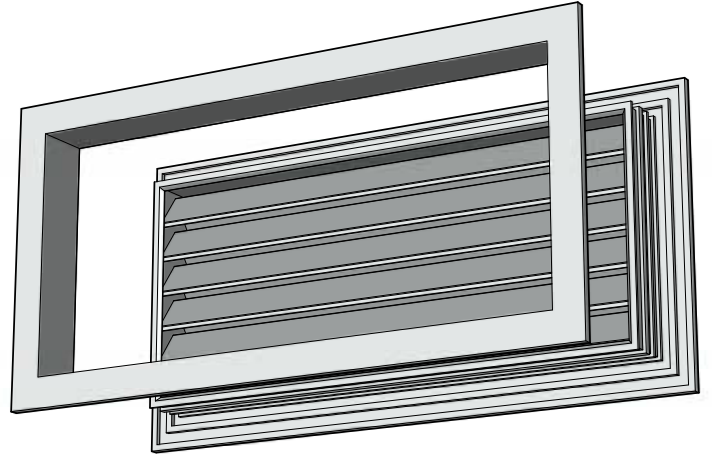
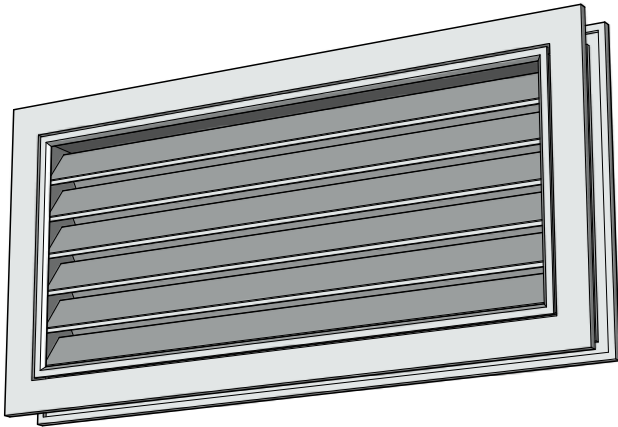

## Product Dimensions

PART NO.	FACE		NOMINAL NECK		EXACT NECK		DOOR THICKNESS	FRONT FLANGE	BACK FLANGE	PITCH
	A	B	C	D	E	F				
DG3015	323	172	300	150	285	135	30 - 40	22.5	20	20
DG6015	623	172	600	150	585	135	30 - 40	22.5	20	20
DG6020	623	223	600	200	585	185	30 - 40	22.5	20	20
DG6025	623	272	600	250	585	235	30 - 40	22.5	20	20
DG6030	623	323	600	300	585	285	30 - 40	22.5	20	20
DG6040	623	423	600	400	585	385	30 - 40	22.5	20	20
DG6045	623	472	600	450	585	435	30 - 40	22.5	20	20
DG6060	623	623	600	600	585	585	30 - 40	22.5	20	20

Drawing dimensions in millimetres

