

Egg Crate Grille Removable Core

Technical Specification Sheet

Egg Crate Grille Removable Core Range of Products

Features

- Used for return air
- Ceiling and wall mounted
- Aluminium construction
- Powdercoat finish
- Standard colour is white
- 10 stock sizes
- Other sizes available upon request*
- Removable core to aid in installation and cleaning
- Available in fixed and loose core
- Neck adapter available to suit in various sizes



Stock Sizes*

ECGRC1515 (150 x 150)
ECGRC2020 (200 x 200)
ECGRC2525 (250 x 250)
ECGRC3030 (300 x 300)

ECGRC3535 (350 x 350)
ECGRC4040 (400 x 400)
ECGRC5929 (595 x 295)
ECGRC5959 (595 x 595)

ECGRC6060 (600 x 600)
ECGRC1159 (1195 x 595)

Explanation of Part Number Structure

Product Group	Product Type	Size (A x B)
Egg Crate Grille	Removable Core	150mm x 150mm
ECG	RC	1515
ECGRC1515		



*Refer web site for details



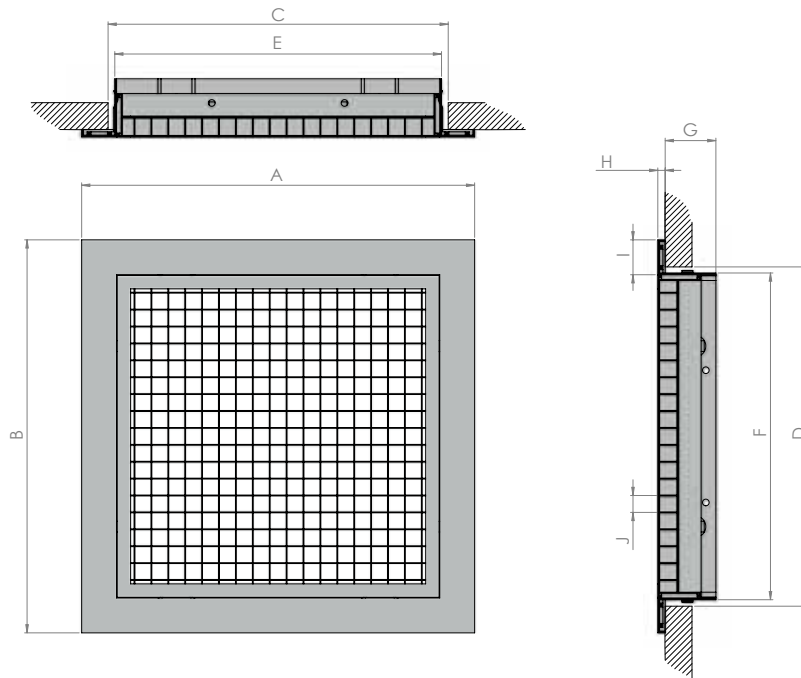
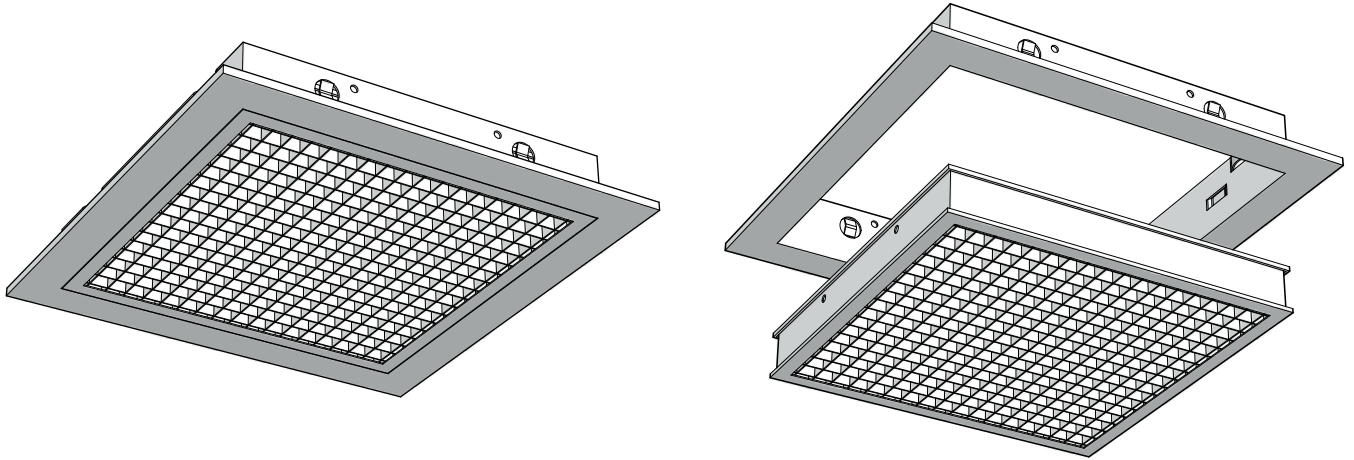

Product Dimensions

PART NO.	FACE		NOMINAL NECK		EXACT NECK		PENETRATION DEPTH	FLANGE THICKNESS	FLANGE	PITCH
	A	B	C	D	E	F	G	H	I	J
ECGRC1515	191	191	150	150	145	145	54	4	25	12.7
ECGRC2020	241	241	200	200	195	195	54	4	25	12.7
ECGRC2525	291	291	250	250	245	245	54	4	25	12.7
ECGRC3030	341	341	300	300	295	295	54	4	25	12.7
ECGRC3535	391	391	350	350	345	345	54	4	25	12.7
ECGRC4040	441	441	400	400	395	395	54	4	25	12.7
ECGRC5929	595	295	554	254	549	249	54	4	25	12.7
ECGRC5959	595	595	554	554	549	549	54	4	25	12.7
ECGRC6060	641	641	600	600	595	595	54	4	25	12.7
ECGRC1159	1195	595	1154	554	1149	549	54	4	25	12.7

Drawing dimensions in millimetres

