

Linear Slot Diffuser Removable Core

Technical Specification Sheet

Linear Slot Diffuser Removable Core Range of Products

Features

- Used for supply or return air
- Typically used in ceiling applications
- Aluminium construction
- Powdercoat finish
- Standard colour is white
- 5 stock sizes
- Other sizes available upon request*
- Available in removable core
- Mounting frame option available
- Available in 20 & 25mm slots
- Available in 1 to 8 slot configurations



Stock Sizes*

LSD202S10 (2 Slot - 1000 x 90)
LSD203S10 (3 Slot - 1000 x 125)
LSD202S12 (2 Slot - 1200 x 90)

LSD203S12 (3 Slot - 1200 x 125)
LSD202S11 (2 Slot - 1195F x 125F)

Explanation of Part Number Structure

Product Group	Product Type		Size (A x B)
Linear Slot Diffuser	20mm Slot Width	Number of Slots	1000mm x 90mm
LSD	20	2S	10
LSD202S10			



*Refer web site for details



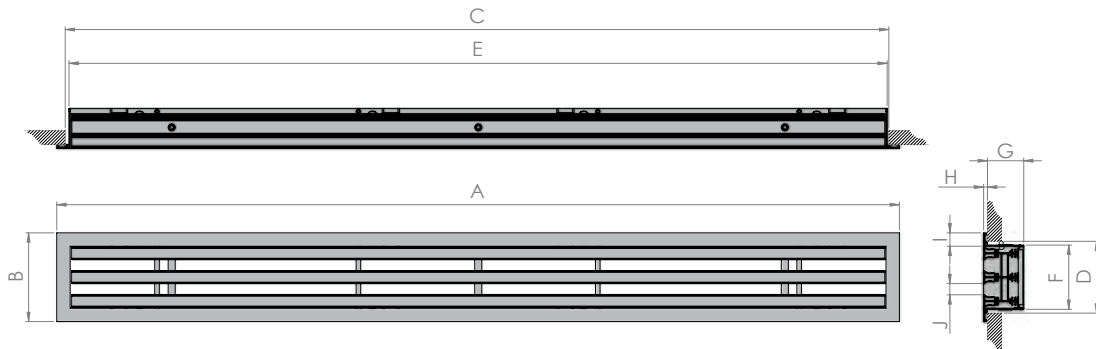
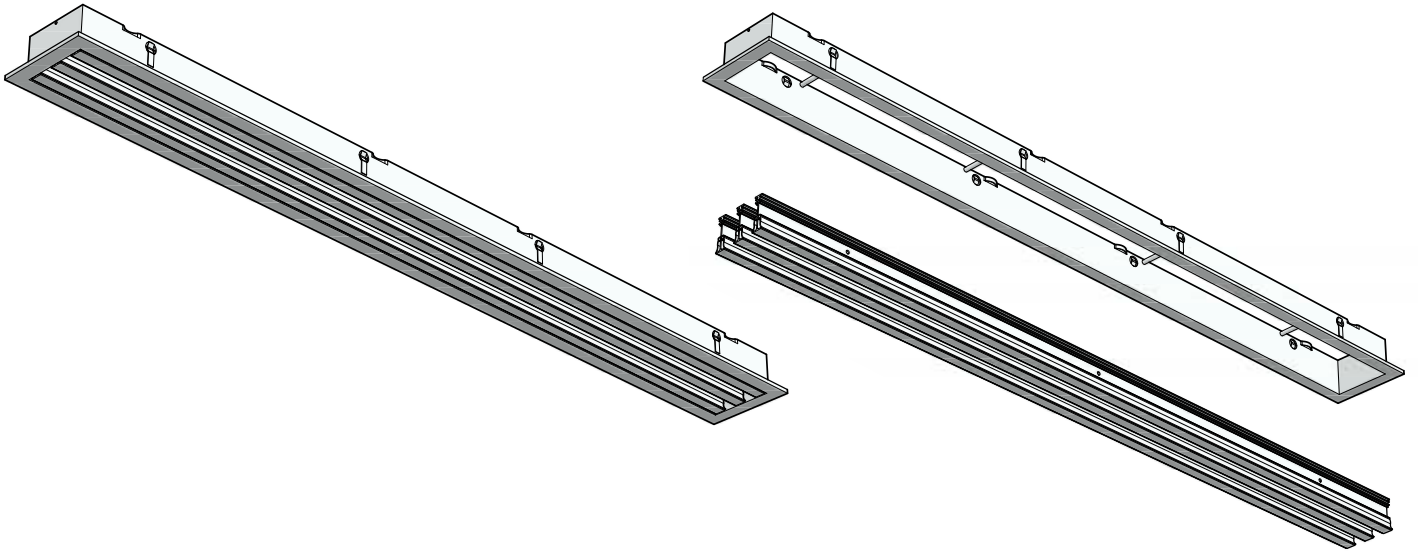

Product Dimensions

PART NO.	FACE		NOMINAL NECK		EXACT NECK		PENETRATION DEPTH	FLANGE THICKNESS	FLANGE	PITCH
	A	B	C	D	E	F	G	H	I	J
LSD202S10RC	1040	125	1005	95	1000	90	52	4.6	19	16
LSD203S10RC	1040	160	1005	130	1000	125	52	4.6	19	16
LSD202S12RC	1240	125	1205	95	1200	90	52	4.6	19	16
LSD203S12RC	1240	160	1205	130	1200	125	52	4.6	19	16
LSD202S59RC	1195	125	1165	95	1160	90	52	4.6	19	16

Drawing dimensions in millimetres

